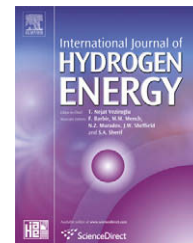

Available at www.sciencedirect.comjournal homepage: www.elsevier.com/locate/he

Reliability of commercially available hydrogen sensors for detection of hydrogen at critical concentrations: Part I – Testing facility and methodologies

L. Boon-Brett^{a,*}, J. Bousek^{a,b}, P. Castello^a, O. Salyk^b, F. Harskamp^a, L. Aldea^c, F. Tinaut^c

^aEuropean Commission, DG Joint Research Centre, Institute for Energy – Cleaner Energy Unit, P.O. Box 2, 1755 ZG Petten, The Netherlands

^bFaculty of Electrical Engineering and Communication, Brno University of Technology, Udolní 244/53, 602 00 Brno, Czech Republic

^cFundación Cidaut, Investigación y Desarrollo en Transporte y Energía (CIDAUT), Parque Tecnológico de Boecillo, 47151 Boecillo, Valladolid, Spain

ARTICLE INFO

Article history:

Received 4 September 2008

Received in revised form

30 September 2008

Accepted 1 October 2008

Available online 14 November 2008

Keywords:

Hydrogen sensor

Hydrogen detection

Safety

Test facility

Performance evaluation

ABSTRACT

A facility for testing the performance of hydrogen safety sensors under a wide range of ambient conditions is described. A specific test protocol was developed to test sensors under conditions which could reasonably be expected during the sensors' service life. The tests were based on those described in IEC 61779 and were adapted following consultation with car manufacturers and after careful consideration of the sensors expected service environmental conditions. The protocol was evaluated by using it to test a large number of commercially available sensors. Observations made and experience gained during the testing campaign allowed the test protocol to be fine-tuned bearing in mind the sensor performance and behaviour during tests. The result of this work is an experimentally evaluated methodology which may be used as a guideline for testing the suitability of hydrogen sensors for automotive applications.

© 2008 International Association for Hydrogen Energy. Published by Elsevier Ltd. All rights reserved.

1. Introduction

Hydrogen is a colourless, odourless and tasteless gas and is, as such, undetectable by human senses. Easy permeation through most materials and rapid diffusion makes hydrogen difficult to contain and store. Furthermore hydrogen has a wide flammability range (4–75 vol%) and at certain concentrations its ignition energy is extremely low. When used as a fuel in stationary or automotive applications its propensity to leak, wide flammability range and easy ignition impose the use of devices to detect and alert to the presence of hydrogen at critical concentrations. With a lower flammability limit (LFL) of just 4.0 vol% in air,

detection of hydrogen is required at low concentrations usually stipulated at either 10% LFL (0.4 vol%) or 25% LFL (1.0 vol%).

Sensitive and reliable hydrogen sensors are therefore essential to enable the detection of leaks when hydrogen is used as a fuel in internal combustion engine or fuel cell vehicles. As a key enabling technology for safety monitoring of hydrogen systems in automotive applications, hydrogen sensors should be accurate, sensitive, respond rapidly, be insensitive to other gaseous species, resistant to long term drift and environmental conditions and capable of reliably alerting to the occurrence of accidental hydrogen releases or leaks before explosive conditions are reached.

* Corresponding author. Tel.: +31 224 565065; fax: +31 224 565623.

E-mail address: lois.brett@ec.europa.eu (L. Boon-Brett).

The conditions for testing flammable gas sensors were issued in 1998 by the International Electrotechnical Commission (IEC) under the title: International Standard IEC 61779-1, electrical apparatus for the detection and measurement of flammable gases – General requirements and test methods [1]. Further standards related to flammable gas detection also exist [2–5] however no standard is specific to hydrogen. Considering the unique properties of hydrogen, concerns exist as to whether existing standards sufficiently cover hydrogen applications. To address this issue a EU funded research project, StorHy [6], assumed as one of its subtasks an investigation of the need for a specific test protocol for hydrogen safety sensors to be used in automotive vehicles [7].

Standard IEC 61779 describes a number of tests to assess the performance of flammable gas sensors. This standard was used as the basis to develop a draft protocol to specifically test hydrogen sensors under conditions representative of their service life in automotive applications. Car manufacturing partners in the StorHy consortium were consulted regarding how far they considered the IEC 61779 as meeting their performance requirements and testing needs for hydrogen sensors envisioned for use in their vehicles. Based on the feedback obtained the test protocol was adjusted and used to test a large number of commercially available sensors. A market survey was made in 2006 to investigate the performance and types of hydrogen sensors available. Following the survey representative samples of the fore most readily available hydrogen sensors types were procured comprising catalytic, electrochemical, thermal conductivity and semi-conducting metal-oxide sensors. All sensors were tested following the protocol developed to experimentally assess their performance and to evaluate the suitability of the procedures used. Observations on sensor behaviour made during the tests allowed further refinement of the test protocol.

2. Hydrogen sensor testing facility

A facility has been designed and built to test the performance of gas sensors and more specifically hydrogen safety sensors. The facility, which is schematically depicted in Fig. 1, is described elsewhere [8–11] but its salient features are summarised here together with modifications made to improve test capabilities.

2.1. Facility description

The facility comprises a test chamber, a gas handling system, a control and data acquisition system, a gas analyser and some subsidiary devices for temperature management and power supply. Central to the facility is the double walled, stainless steel test chamber into which sensors are mounted. The vessel, with an inner volume of 2.4 l, is internally coated with HALAR[®] polymer for chemical resistance and is further contained inside another vessel, which can be closed and purged with an inert gas flow. In this way the test chamber is isolated from laboratory environment, thereby improving thermal stability and ensuring safety of operation when toxic or flammable gas mixtures are used. Depending on the size of the sensors being tested up to six samples can be mounted in the chamber, out of contact with the walls. Simultaneous testing of several sensors ensures identical test conditions for all samples thereby allowing a direct comparison of the sensors' performances to be made. All electrical signals, including sensors' inputs and outputs are transferred into and out of the chamber by means of two 25-pin feedthroughs. The test gas is introduced into the bottom of the test chamber and leaves from the top. A small fan positioned inside the chamber ensures homogeneity of temperature distribution and gas

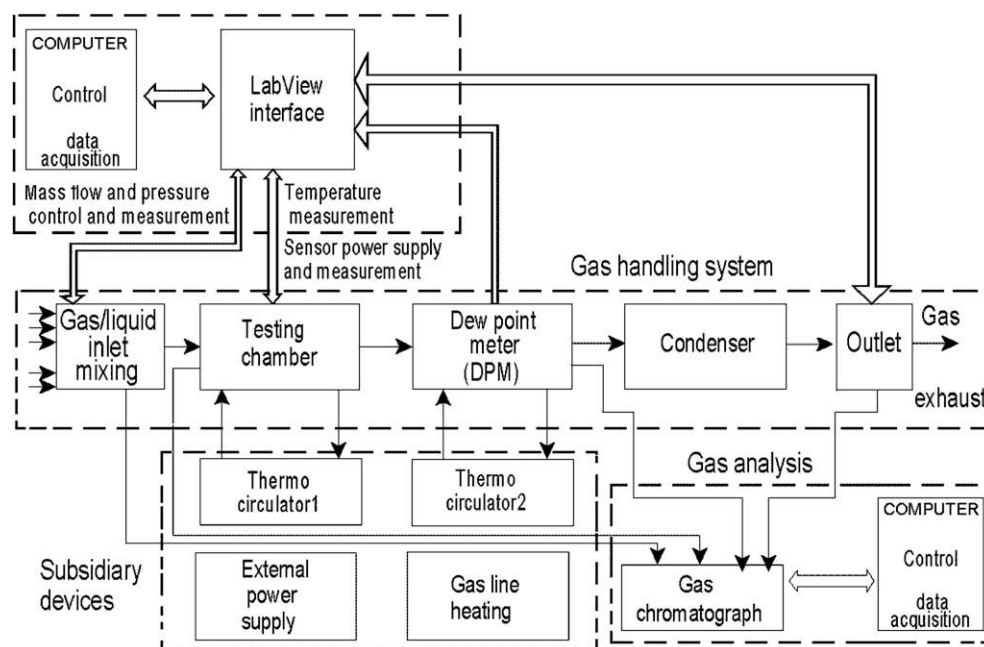

Fig. 1 – Schematic diagram of sensor testing facility.

composition. Between tests care was taken to ensure that all gases and vapours used were thoroughly flushed out of the chamber to remove all traces of these species before starting the subsequent test. Moreover the gas piping is heated to prevent condensation of water vapour on the internal walls.

A series of mass flow controllers are used to control the flow rates of up to four gases or gas mixtures into the system. This method of online gas mixing allows a wide range of gas compositions to be prepared and introduced into the chamber and is described in more detail below. Temperature in the chamber is controlled by circulating a thermostatic fluid between the chamber walls. Temperature in the chamber is measured by means of three Pt100 thermometers connected to the LabView® data collecting system. When needed, water is evaporated into the test gas by means of a Bronkhorst® controlled evaporator mixer (CEM). Based on the water/gas ratio introduced into the CEM the relative humidity of the gas can be estimated from the water vapour pressure and ambient temperature. These were derived from tables and web-based tools maintained by the CEM manufacturer [12]. Proper operation of the liquid/vapour mixing system is monitored through independent measurement of the test gas humidity by means of a chilled mirror dew point meter.

The gas flow and pressure control system have been reconfigured to remove pressure and gas flow instabilities which had been reported previously [8]. The modified system is shown schematically in Fig. 2. Gas enters the facility through one of four inlet mass flow controllers (MFC 1–4). These gases pass through a gas mixer (Bronkhorst®) where they are mixed thoroughly. An upstream pressure controller (PRC 1) controls the pressure of the inlet gases. They then pass through mass flow controller MFC 5 or MFC 6 which controls the gas mass flow through the test chamber. The function of PRC 1 is to avoid a pressure build-up in the inlet which could block the flow of gases through the inlet mass flow controllers thereby affecting the gas mixture composition. In the event of

pressure build-up PRC 1 opens and the gas is released. Its flow is measured by the mass flow meter MFM 1 before bypassing the test chamber and exiting the facility via the exhaust. The pressure in the chamber is controlled by an upstream pressure controller, PRC 2.

The actual composition of the gas is continuously analysed during tests by a multi-column, multi-detector (thermal conductivity and flame ionisation detector) and compact gas chromatograph (GC). The GC was calibrated for hydrogen quantification for the purpose of these tests. Random tests were performed during and after the sensor testing campaign to check the accuracy of the hydrogen concentration measurements by the GC. These tests, performed with certified calibration gases, showed that the GC was able to measure the hydrogen concentration within $\pm 5\%$. Test gas samples can be taken from 11 different points in the facility and sent to the gas chromatograph (GC) for independent quantitative analysis. The pressure in the GC sample loop is controlled by the downstream pressure controller PRC 3 while mass flow controller MFC 7 controls the flow of gas to be analysed.

The facility is controlled by National Instruments™ hardware and is managed through software programmed in LabVIEW™. The software controls both gas and liquid mass flow controllers and pressure settings via an Ethernet 100 port with a Fieldpoint 2000 communication and control block (National Instruments). At the same time, it acquires and stores data on flows, pressures, dew point, temperature and sensor signals through eight analogue inputs with 12-bit resolution.

2.2. Facility test capabilities

Hydrogen in air mixtures can be routinely prepared containing hydrogen in concentrations as low as 0.03 vol%. Lower concentrations are also possible if required. The maximum hydrogen concentration used during tests was limited to 2.0 vol% for safety reasons. Temperature in the test chamber

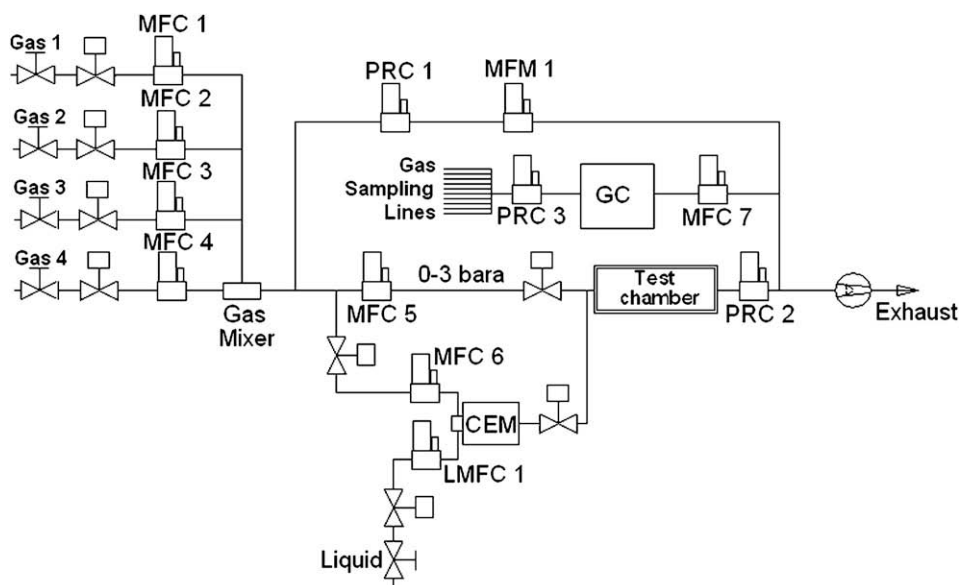

Fig. 2 – Modifications made to the sensor testing facility. A by-pass prevents pressure build-up and allows more accurate control of gas flow and composition during tests. Test gas samples can be taken from up to 11 different points in the facility and sent to the gas chromatograph (GC) for independent quantitative analysis.

can be controlled between $-40\text{ }^{\circ}\text{C}$ and $+130\text{ }^{\circ}\text{C}$ and can be held at constant temperature within $\pm 2\text{ }^{\circ}\text{C}$. Pressure changes between 80 kPa and 110 kPa are sufficient to simulate reasonable variations in altitude however the pressure range of the facility is about 100 Pa–250 kPa. Relative humidities of 10% at $-10\text{ }^{\circ}\text{C}$ and 100% at $60\text{ }^{\circ}\text{C}$ are possible. At lower or higher temperatures, the relative humidities achievable increase and decrease respectively. A total of four different gases may be mixed to produce the particular gas composition desired. In addition two liquids, one of which is usually water, may be simultaneously introduced, evaporated and mixed with the gas before entering the test chamber containing the sensors.

3. Test methodology

A hydrogen safety sensor performance test protocol has been formulated based on the International Standard IEC 61779-1. The test protocol is specifically designed for testing hydrogen sensors which may be used for detecting unwanted hydrogen leaks and releases in future hydrogen fuelled vehicles. As mentioned previously the tests described in IEC 61779 were modified following consultation with car manufacturers to take into consideration their expectations with respect to the sensor performance requirements. The working environment of the sensors was also taken into careful consideration.

A protocol was drawn up for the following performance tests:

1. Accuracy of response test
2. Measuring range test
3. Detection limit test
4. Cross sensitivity to carbon monoxide test
5. Ambient temperature test
6. Ambient relative humidity test
7. Ambient pressure test

These tests were identified as being of immediate interest by the car manufacturers. They will be supplemented in the future with further tests. Up to six sensors were mounted in the chamber at a time. Sensor performance was assessed based on the results from these tests and the performances of sensors were mutually compared. In this work no attempt was made to perform tests under multi-variable conditions (e.g. to investigate the combined influence of temperature and humidity changes on sensor response). Instead only single variable performance tests were requested and performed within the scope of this project. The following sections describe the methods followed for each test.

3.1. Accuracy of response test method

The aim of this experiment is to determine the accuracy of sensor response to changes in hydrogen concentration. An accuracy of $\pm 5\%$ was considered by the car manufacturers as acceptable. Sensors were mounted in the chamber and were exposed to a gas mixture whose hydrogen concentration was changed stepwise between 0.0 vol% H_2 and 2.0 vol% H_2 (maximum) by online mixing of 2.0 vol% H_2 in air with synthetic air. The test was performed in a stepwise fashion instead of

a continuous fashion for reasons detailed in Section 4. Hydrogen concentration was changed stepwise by increasing and then decreasing the relative 2.0 vol% H_2 in air flow rate in synthetic air. Following each step both sensor signals and GC measurements were allowed to stabilise before proceeding with the subsequent step. Sensor outputs and the corresponding hydrogen concentration (measured by the GC) were recorded and compared to assess the accuracy of the sensor response.

The accuracy of response test was performed immediately prior to the measuring range test described below. During the combined tests the hydrogen concentration was increased and then decreased for three cycles - the first cycle in a stepwise fashion (accuracy test) and the remaining two cycles in a continuous fashion (measuring range test) under identical test conditions. Fig. 3 shows how the synthetic air and 2.0 vol% H_2 in air flow rates were controlled to achieve the stepwise and continuous changes in hydrogen concentration.

The standard testing conditions for the accuracy and measuring range tests were

Temperature: $298\text{ K} \pm 2\text{ K}$ ($25\text{ }^{\circ}\text{C} \pm 2\text{ }^{\circ}\text{C}$)

Pressure: $100\text{ kPa} \pm 2\text{ kPa}$

Relative humidity: 50% RH (dew point $13.8\text{ }^{\circ}\text{C} \pm 1.8\text{ }^{\circ}\text{C}$)

Gas flow rate: $1000\text{ nml/min} \pm 20\text{ nml/min}$

3.2. Measuring range test method

The aim of this experiment is to monitor the response of sensors to changing H_2 concentrations. Sensors were exposed to hydrogen plus synthetic air at different volume ratios in the range 0.0–2.0 vol% hydrogen, starting with the lowest and finishing with the highest of the selected volume ratios. This operation was carried out immediately after the accuracy of response test (see Fig. 3) and was performed two times consecutively. Repeating the procedure reveals any memory effects or hysteresis behaviour of the sensors.

3.3. Detection limit test method

The aim of this test is to determine the lowest concentration of hydrogen which can be detected by a sensor. Some

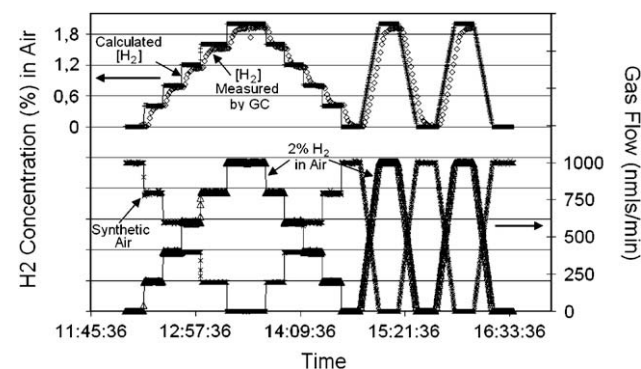

Fig. 3 – Example of control and measurement of hydrogen concentration during accuracy and measuring range tests. The theoretical hydrogen concentration was calculated from the relative mass flows of synthetic air and 2 vol% H_2 in air.

automobile manufacturers specified a detection limit of <0.1 vol%, others accepted a detection limit of <0.2 vol%. The test was performed by online mixing of 2.0 vol% hydrogen in air and synthetic air at different volume ratios in the range from 0.0 vol% to approximately 0.4 vol% hydrogen, starting with the lowest and finishing with the highest of the selected volume ratios. Sensors were initially exposed to synthetic air and a baseline was recorded. The 2.0 vol% hydrogen in air flow rate was then gradually increased in a stepwise manner (as shown in Fig. 4) until a well defined step in sensor output was observed in response to the change in hydrogen concentration. Stepwise increase/decrease of the hydrogen volume fraction was preferably performed in a sequence of values multiple of a base step (for example in the sequence 1 \times , 2 \times , 3 \times , 5 \times , 10 \times ...). The stable signal indication was recorded as was the hydrogen concentration. The hydrogen concentration was brought gradually back to zero and the procedure was repeated a further two times.

This test was carried out under conditions of temperature, pressure, gas flow and humidity within the range indicated by the sensor manufacturer, similar to those during the accuracy of response and measuring range tests.

An example of control of hydrogen concentration during detection limit tests is shown in Fig. 4. During this test hydrogen concentrations were varied stepwise for three cycles comprising six different hydrogen concentrations between 0.0 vol% and 0.3 vol%.

3.4. Cross sensitivity to carbon monoxide test method

Cross sensitivity of any chemical sensor should be low to prevent inference in sensor response from other contaminant species. Automotive manufacturers expressed the most interest in the cross sensitivity of hydrogen sensors to carbon monoxide. During the test the flow rate of 2.0 vol% H_2 in air was kept constant (thereby maintaining a constant hydrogen concentration) and the relative flows of synthetic air and 0.5073 vol% CO in nitrogen were varied stepwise to vary the concentration of CO in the gas mixture. Stepwise increase/decrease of the carbon monoxide volume fraction was preferably performed in a sequence of values multiple of a base step (similar to the sequence described in the detection limit test) however the exact sequence varied between tests

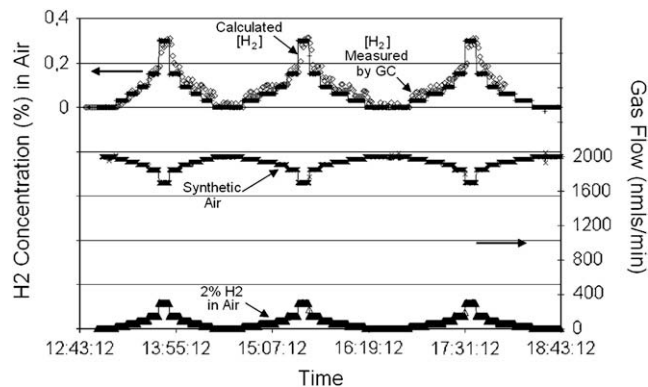

Fig. 4 – Example of control and measurement of hydrogen concentration during detection limit tests.

depending on the response of the sensors being tested. The CO concentration was increased in this way until the sensor gave a signal deviation equivalent to 0.4 vol% H_2 (10% LFL). The sensor cross sensitivity to carbon monoxide is expressed as the concentration of CO required to give this signal deviation. The maximum achievable CO concentration was 0.4 vol%. For sensors which exhibited a low cross sensitivity to CO (i.e. their signal deviation to the maximum achievable CO concentration was less than 0.4 vol% H_2) the concentration of CO necessary to give the required signal deviation was estimated by extrapolation of the cross sensitivity results observed. It was observed that the cross sensitivity of some sensors to CO may differ depending on whether the test is performed in the absence of hydrogen or at different hydrogen concentrations. Similar observations of variation in sensor response to H_2 and CO gas mixtures have also been reported by others [13].

Due to the low accuracy of the GC with respect to CO measurements at concentrations below 0.4 vol% the CO concentration was calculated from the gas flow rates and not taken from the GC measurements. Fig. 5 shows an example of the stepwise change in CO concentration during a typical cross sensitivity test and the response of a catalytic sensor to this change in CO concentration. During the test the hydrogen concentration was held constant at 0.91 vol% and the sensor response to this concentration ('reference level') was 1.14 vol%. Increasing the CO concentration caused a non-linear increase in sensor response and at 0.254 vol% CO the deviation in the sensor response was equivalent to +0.634 vol% H_2 . The cross sensitivity of this sensor to CO was interpolated to be 0.21 vol% CO (i.e. 0.21 vol% CO gave a sensor signal deviation of 0.4 vol%).

3.5. Ambient temperature test method

The aim of this test was to assess the influence of temperature on the sensor output signal in the absence of H_2 and in the presence of H_2 in concentrations up to 2.0 vol% H_2 in air. Temperature was increased in five steps within the temperature range specified by the manufacturer and at each step the temperature in the chamber was maintained within ± 2 °C. At

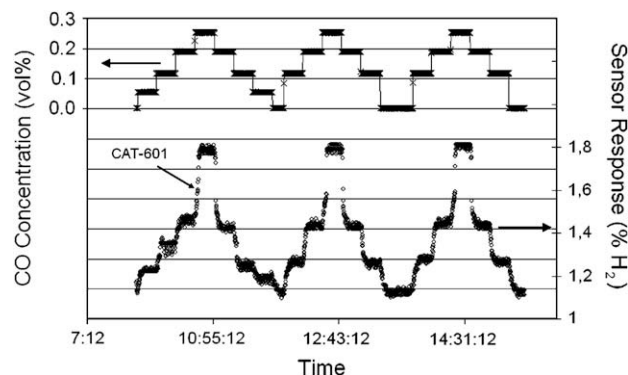

Fig. 5 – Cross sensitivity to carbon monoxide demonstrated by the catalytic sensor CAT-601. Hydrogen concentration was held constant at 0.91 vol% and the sensor response at this concentration, and in the absence of CO, was 1.14 vol%. Note the non-linear dependence of sensor response to CO.

each temperature the sensors were exposed to synthetic air and then subsequently to the hydrogen in air mixture. To prevent condensation in the chamber it was imperative to keep the gas dew point below that of the lowest test temperature effectively meaning that temperature tests were performed close to dry gas conditions. When the temperature in the chamber had stabilised at the set value a zero sensor reading was taken in a gas flow comprising synthetic air only. Following this the flow of 2.0 vol% H₂ in air was started to give the desired H₂ concentration. When the sensor signal had stabilised the sensor response was recorded before proceeding to the next temperature. An operating temperature range of -40 to $+85$ °C was deemed desirable by automobile manufacturers. However during temperature tests the operating range of the sensors being tested, as specified by the manufacturer, was always respected so that no sensor was tested outside its temperature range.

Fig. 6 shows a typical temperature profile during a temperature test on two metal-oxide semiconductive (MOx) sensors. Sensors were heated or cooled to five different temperatures chosen within the operating temperature range specified by the manufacturer. Fig. 6 also shows how hydrogen concentration was varied between 0.0 vol% and 0.2 vol% at each temperature step. It is clear from this test that temperature has little to no effect on the MOx sensor zero reading however it has a profound effect on the sensor reading in 0.2 vol% hydrogen with evidence of hysteresis.

3.6. Ambient humidity

The aim of this experiment is to determine the influence humidity has on the sensor signal in synthetic air and in the presence of hydrogen in concentrations up to 2.0 vol% H₂ in air. Automobile manufacturers indicated a desired operational humidity range of 0–95%. According to the IEC 61779-1 test protocol test gas with at least three different humidities evenly distributed over the range specified by the sensor manufacturer was supplied to the sensor in the test chamber which was maintained at a constant temperature and pressure. The humidity deviation was maintained within $\pm 3\%$ RH of the desired humidity. The sensors were exposed first to synthetic air and then to a test gas comprising up to 2.0 vol%

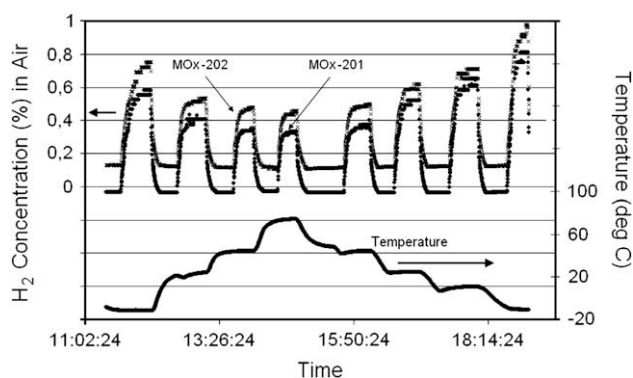

Fig. 6 – The variation in response of MOx sensors to hydrogen as a function of temperature. At each temperature, the hydrogen volume concentration was changed between 0.0 vol% and 0.2 vol%.

H₂ in air at the same humidity levels. The results of a typical humidity test performed on four electrochemical sensors in 0.0 vol% and 1.5 vol% H₂ are shown in Fig. 7. From this figure it is obvious that the response of these electrochemical sensors did not vary significantly with humidity in the range investigated. Note that when the sensors were initially exposed to 1.9 vol% H₂ in air, two sensors showed a hydrogen concentration higher than 4.0 vol% equivalent to their measuring range upper limit. For this reason it was decided to limit the maximum H₂ concentration to which these sensors were exposed to 1.5 vol% H₂ in air.

3.7. Ambient pressure test method

The aim of this test is to determine the influence of pressure on the sensor output in the absence of H₂ and in the presence of hydrogen at concentrations up to 2.0 vol% H₂ in air. In automotive applications a reasonable altitude range is from -400 m to 4000 m. These altitudes correspond to approximate atmospheric pressures equal to 107 kPa and 62 kPa [14]. During this test the pressure in the test chamber was set to at least three different pressures within the pressure range specified by the sensor manufacturer and the sensors exposed to air and then up to 2.0 vol% H₂ in air. The pressure deviation was maintained within ± 2 kPa for at least 5 min to allow conditions to stabilise before a sensor reading was taken. At each pressure the sensor was exposed first to synthetic air and a zero reading was taken before being exposed to hydrogen at a concentration up to 2.0 vol%. The results from a pressure test performed on two identical MOx sensors are shown in Fig. 8. During this pressure test the hydrogen concentration as measured by GC analysis is corrected for changes in the total pressure and the corrected measured hydrogen concentration is shown together with the sensor readings. At all pressures these sensors show a significant overestimation of the

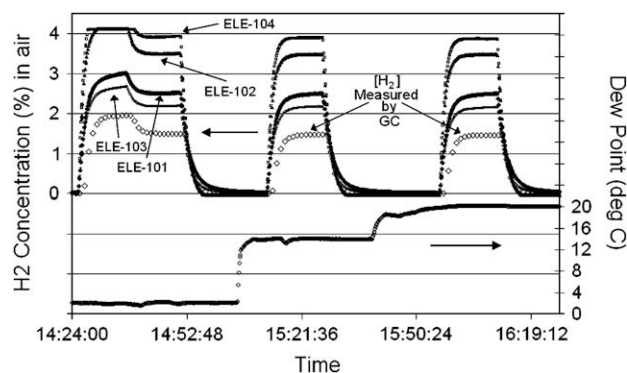

Fig. 7 – The influence of humidity on electrochemical sensor response. At each humidity hydrogen concentration was changed between 0.0 vol% and 1.5 vol% H₂ in air. The equivalent relative humidities to the measured dew points of 1.5 °C, 14.5 °C and 20 °C are 20%, 50% and 70% (at chamber temperature 26 °C) respectively. When the sensors were initially exposed to 1.9 vol% H₂ in air, two sensors were saturated showing their limit of the range and for this reason it was decided to limit the maximum H₂ concentration to which these sensors were exposed to 1.5 vol% H₂ in air.

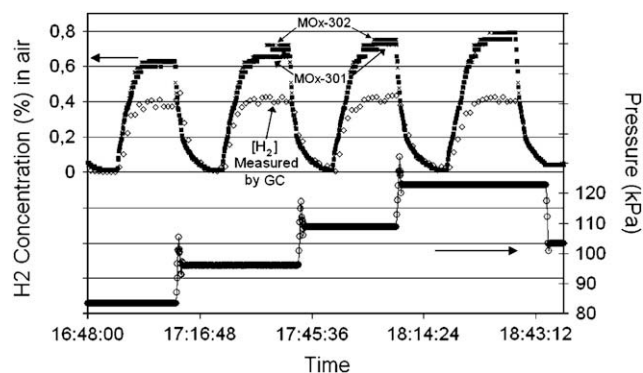

Fig. 8 – The response of two MOx sensors to 0.0 vol% and 0.4 vol% H₂ in air at four different pressures.

hydrogen concentration and as expected the sensor output increases with increasing pressure.

4. Observations and test method development

Within the framework of the StorHy integrated project the ultimate aim of this work is to independently test the performance of hydrogen sensors' behaviour and to assess and compare the different sensor technologies currently available on the market and analyse their suitability for application in the automotive industry. The previous section described the tests performed on commercially available hydrogen sensors and the results from these tests are presented and analysed in detail in Part II of this series. During the testing campaign a number of observations were made some of which were used to fine-tune the test protocol and to make it more specific to performance testing of hydrogen safety sensors for use in automotive applications. These observations and improvements to the test protocol are described in this section.

4.1. Electrical connections and representation of sensor reading

The outputs of the different sensors tested were one of four different types:

- 4–20 mA current loop which is the industrial standard,
- 0.5–5 V voltage output which is also common and easy to handle,
- CANBUS output which is quite sophisticated and allows easy integration into car electronics and is ideal for automotive applications,
- Voltage output in a half bridge configuration, usually with the possibility to use a control unit supplied by the manufacturer.

In order to compare the response of sensors the processed signal sensor outputs were converted from either electrical current or voltage into hydrogen concentrations (expressed in H₂ vol% in air) using the sensor sensitivity provided by the

manufacturer in the sensor specifications. In this way individual sensor responses could be compared with each other and also with the hydrogen concentration as measured by the gas chromatograph.

4.2. Oxygen requirement

Most sensor types require oxygen to operate properly. Catalytic sensors need oxygen to complete the combustion reaction, metal-oxide (MOx) sensors need oxygen to ensure the equilibrium of oxidation–reduction processes on the surface of the sensitive layer and oxygen is generally essential for electrochemical sensors to define the electrochemical potential in the electrode system. In principle thermal conductivity sensors do not need oxygen for proper operation. Nevertheless, if the concentration of oxygen changes enough to cause a significant change in the thermal conductivity of the ambient gas then different concentrations of oxygen may influence the sensor reading. For these reasons all sensors tests were performed in synthetic air to eliminate any influence on the sensor readings due to insufficient oxygen or variations in oxygen concentration.

4.3. Modification of ambient humidity test method

During the testing campaign it was found that humidity has a profound effect on some types of hydrogen sensors, most notably metal-oxide (MOx) sensors and to a lesser extent thermal conductivity sensors. The extent of this influence is highlighted in Fig. 9 which shows the response of four MOx sensors (2 different models) to 0.35 vol% H₂ in air at different humidities. The sensors largely overestimated the hydrogen concentration at 15% RH. However increasing the humidity caused a further increase in sensor signal such that at 30% RH one sensor (MOx-201) had reached its signal limit and at around 35% RH sensor MOx-202 had also reached its signal limit. Therefore sensors MOx-201 and MOx-202 both reached

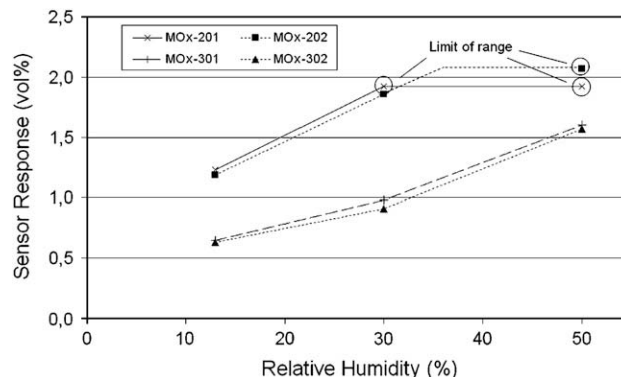

Fig. 9 – Change in the response from four MOx sensors at different ambient humidities. Hydrogen concentration during this test was 0.35 vol%. All sensors overestimated the real hydrogen concentration. In addition, sensors MOx-201 and MOx-202, both reached their signal limit at a hydrogen concentration far below the upper measuring range limit which was given as 2.0 vol% by the manufacturer.

saturation at a hydrogen concentration far below the upper measuring range limit (given as 2 vol% by the manufacturer) under normal ambient conditions including 35% RH.

Considering this influence and also considering the large range of relative humidities which a sensor could realistically be exposed to during its service life in automotive applications a more thorough humidity test is deemed necessary. Therefore, humidity tests were performed preferably at five different relative humidities contrary to Standard IEC 61779-1 where testing at three different relative humidities is deemed sufficient.

4.4. Test gas hydrogen concentration

As mentioned previously some hydrogen sensors had a very large response to changes in ambient parameters. For sensors strongly influenced by ambient conditions an adaptation to the test protocol with respect to the test gas hydrogen concentration is required to enable ambient parameter influences to be fully apparent. In this case ambient parameter tests should be carried out using test gas having a hydrogen concentration at which the sensor output falls in the middle of the sensors real measuring range.

4.5. Identification of facility time delays

During test the composition of the test gas mixture was controlled by setting the mass flow rate of the respective gases. Samples of gas mixture were continuously taken from the test chamber and analysed independently to determine the actual hydrogen concentration the sensors were exposed to. It was also possible to calculate the theoretical hydrogen concentration based on the flow rates of synthetic air and 2.0 vol% H₂ in air given by the respective mass flow controllers. The measured hydrogen concentration and the computed hydrogen concentration from a measuring range test performed on catalytic sensors are shown in Fig. 10. A time delay between both the curves can be clearly seen and corresponds to:

- The time taken for the gas to reach the sensor chamber.
- The time taken for a gas sample to be taken from the test chamber and injected onto the GC column.
- The analysis time corresponding to the passage of hydrogen through the column, elution from the column and subsequent detection by the thermal conductivity detector.
- The time associated with mixing of the gases.

Consequently it is impossible to measure the exact hydrogen concentrations during the increasing or decreasing ramp phase of the test because of non steady state conditions and the time delays involved which can be not easily eliminated. A reliable value of hydrogen concentration can only be obtained after the GC reading has stabilised on the plateau – several minutes after the ramp phase ends.

4.6. Estimation of facility time delays

To obtain more insight into time relations of sensor response to changes in gas composition the step control of the gas flow

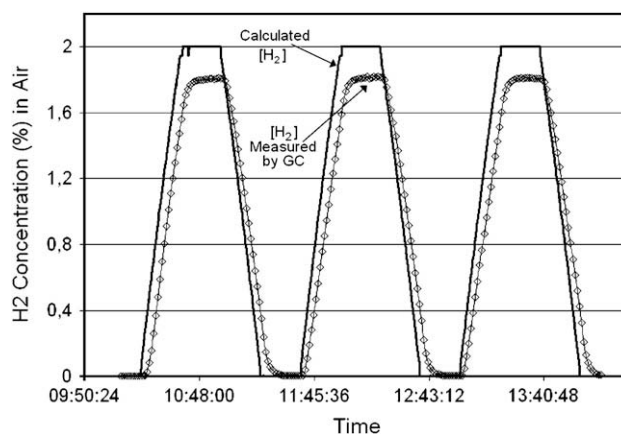

Fig. 10 – Variation of the hydrogen concentration during a measuring range test. Note the delay of the gas chromatograph reading and the discrepancy between the maximum calculated and measured concentrations as mentioned in Section 4.9. The error associated with the GC measurements is less than $\pm 5\%$ and does not fully explain the significant difference between the GC measurements and the calculated hydrogen concentration.

rate is more convenient. The hydrogen concentration measured by GC and the theoretical hydrogen concentration are shown in Fig. 11. In this case the hydrogen concentration was changed rapidly from 1.6 vol% to 1.22 vol% and the response of three catalytic sensors was monitored. The sensor outputs are shown in Fig. 11 together with the calculated hydrogen concentration and the hydrogen concentration measured by the GC. In this figure time zero corresponds to the time when the hydrogen mass flow controller starts to close and when the calculated hydrogen concentration begins to drop.

From this figure a number of time delays can be identified and quantified:

- The transport delay between the gas flow controllers and test chamber is about 45 s.

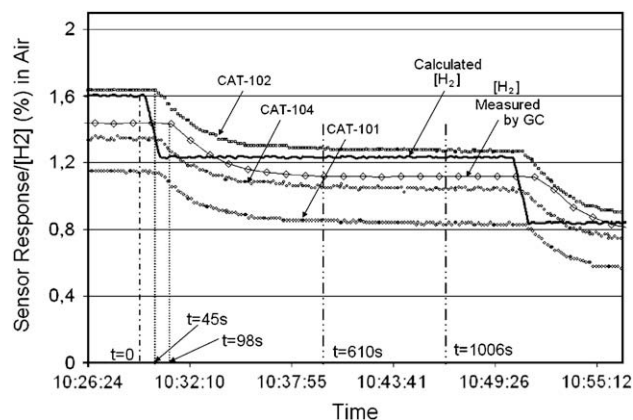

Fig. 11 – Stepwise decrease in hydrogen concentration from 1.6 vol% to 1.22 vol% and the response of the gas chromatograph and three catalytic sensors to this change. The total gas flow rate was 1000 nml/min.

- The transport delay between the test chamber and the GC which is about 53 s indicating that the GC starts to respond about 98 s after the flow of hydrogen is changed.
- Both sensor and GC readings are very close (>90%) to their steady state value after approximately 610 s. Steady state is reached at approximately 1000 s after the hydrogen flow was changed. This delay is caused by gas-mixing delay and by the reaction time of sensors and that of GC. It can be seen from Fig. 11 that the response time of the catalytic sensor is approximately the same as the GC response time. Similar time delays were observed following other hydrogen concentration step changes.

Considering time relations given in Fig. 11 an important rule is obvious: To eliminate any inaccuracies due to time delays all data readings should be taken under steady state conditions which, for these tests, were at least 10 min after the gas flow settings or ambient conditions changed.

4.7. Water production and effect on humidity control

During tests on catalytic sensors, and to a lesser extent on electrochemical sensors, significant changes in the dew point were observed. The variation in dew point during the measuring range test on three catalytic sensors is shown in Fig. 12. The dew point of the gas mixture was measured by the chilled mirror dew point meter and was set at 11.7 °C at the start of the test. When the hydrogen concentration was increased the dew point reading was observed to increase due to the production of water from the catalytic oxidation of hydrogen as a consequence of sensor operation. A corresponding decrease in the dew point reading was observed when the hydrogen concentration was decreased. The dew point of the gas mixture increased to 14.2 °C when the actual hydrogen concentration and consequently the sensor signal output were at a maximum. In the absence of hydrogen the dew point dropped to 12.5 °C. This change in the dew point from 12.5 °C to 14.2 °C is equivalent to a relative humidity (RH) change from 47% to 53% at a temperature of 24 °C (297 K). This

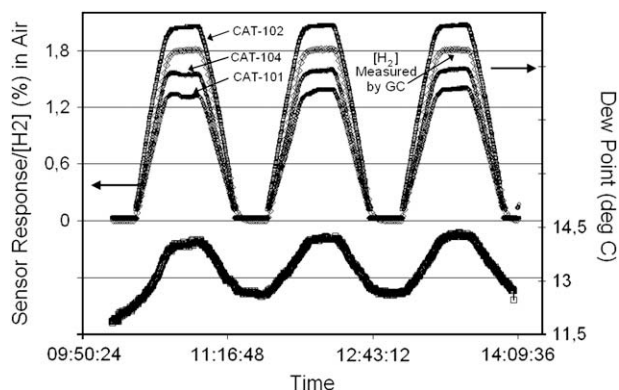

Fig. 12 – Change in dew point observed during tests on catalytic sensors. When the hydrogen concentration was increased the dew point increased simultaneously due to the production of water from the catalytic oxidation of hydrogen by the sensors.

means that in this case the RH deviates by only $\pm 3\%$ from the mean value 50%. This variation falls within the acceptable RH deviation defined in the test protocol derived from IEC 61779-1.

4.8. Hydrogen concentration range

The facility allows simultaneously testing of several sensor samples. In the event that different sensor types or models are tested care was taken to ensure that the conditions for the tests were carefully set within the operating limits of all samples. It was observed during several tests that the maximum hydrogen concentration which could be measured by some sensors was considerably lower than the upper limit specified by the manufacturer. Fig. 13 illustrates the large variation in results which was obtained during the accuracy and measuring range tests performed on four identical electrochemical sensors with measuring range from 0.0 vol% up to 4.0 vol% hydrogen. Sensor ELE-104 reached its limit of range at a concentration of 1.5 vol% hydrogen and sensor ELE-102 reached its limit of range at a concentration of 1.8 vol% hydrogen. Similar behaviour of these sensors may be also seen in Fig. 7. Consequently, in such cases it is necessary to carefully select the hydrogen concentration range used during tests to avoid response saturation of some sensors.

4.9. Consumption of hydrogen

In Fig. 10 a discrepancy can be seen between the maximum theoretical H_2 concentration (2.0 vol%) and the maximum measured H_2 concentration (1.8 vol%). This difference can be attributed to the consumption of H_2 by, in this case, three catalytic sensors in the test chamber. A similar discrepancy was also observed during tests on electrochemical sensors where the measured hydrogen concentration was 5% lower than the calculated hydrogen concentration. Although these differences in hydrogen concentration decrease at higher gas flow rates they cannot be eliminated completely. For this reason the hydrogen concentration in the gas to which the sensors were exposed in the test chamber, was always measured by independent gas analysis during all tests.

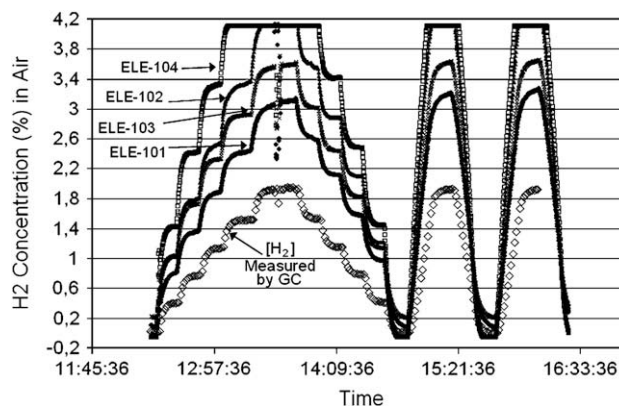

Fig. 13 – Response of four electrochemical sensors to changes in hydrogen concentrations during accuracy and measuring range tests.

5. Results and conclusion

The results of this work have been the design and construction of an improved facility for testing hydrogen safety sensors and the development of an experimental protocol to test the performance of these sensors under representative service life conditions for use in automotive applications. Hydrogen sensors have been identified as an enabling technology directly linked to the safe demonstration of hydrogen vehicles [15].

The facility allows the preparation of a wide range of test gas compositions under varying conditions of temperature, pressure and relative humidity. The modular design of the facility allows easy introduction of other species including liquids and gases. Performance tests which were based on those described in IEC 61779-1 were adapted after consultation with a number of car manufacturers in order to meet their specific sensor performance and testing needs. Careful consideration was also given to the expected environment of the sensors during their service life. The protocol was verified by using it to test and evaluate samples of commercially available sensors which were procured following an extensive market survey. In Part II of this series the full results and conclusions of sensor performance test results are presented.

During initial tests, performed as part of the development of the test protocol, it was apparent that many sensors displayed unexpected behaviour, deviating not only from the manufacturer's specifications but also showing a wide variation in response between identical sensors. Moreover several sensors available for testing either failed to give a signal or failed to respond to the presence of hydrogen. The relatively large proportion of 'failed' samples may have been due to damage caused during transportation, handling or electrical connection of these sensors however these reasons are speculative. A larger sample number for testing is required before any relationship between the number of 'failed' samples and sensor reliability can be made.

The developed test protocol may be used as a guideline to test hydrogen sensors suitable for detecting unwanted hydrogen leaks in future hydrogen fuelled vehicles under representative service life conditions. In addition to being used for sensor performance assessment a harmonised test procedure can also be used for inter-laboratory comparisons or round-robin testing of hydrogen sensors. It is the authors' experience that, considering the sometimes unexpected behaviour of sensors, independent testing of safety sensors will play an important role in identifying R&D needs and offering feedback to sensor manufacturers and end-users. When used as devices for ensuring public safety it is essential that hydrogen sensors can reliably detect critical concentrations of hydrogen defined in this work as 10% LFL (0.4 vol%). Independent assessment and demonstration of the proper performance of such devices can help facilitate a transition to a hydrogen-inclusive economy by increasing consumer confidence in and improving the public's perception of hydrogen safety [16] and ultimately increasing its acceptance.

Acknowledgements

Partial funding by the European Commission DG Research (contract SES6-CT-2004-502667/StorHy) is gratefully acknowledged. The authors would also like to thank partners from the StorHy consortium for their contribution to this work particularly the automobile manufacturers.

REFERENCES

- [1] International Standard IEC 61779-1. Electrical apparatus for the detection and measurement of flammable gases. Parts 1 of 6. 1st ed. International Electrotechnical Commission (IEC); 1998.
- [2] Underwriters Laboratories (UL). Standard for gas and vapor detectors and sensors, underwriters standard ANSI/UL 2075. Canada: UL Inc. Publishers; 2004.
- [3] Canadian Standards Association. Combustible gas detection instruments Canadian electrical code part 2, industrial products, standard CSA-C22.2 No 152-M1984 (R2006); 2001.
- [4] Japanese Standards Association. Portable type combustible gas detector M7653 JISM7653-1996; 1996.
- [5] Japanese Standards Association. Stationary type combustible gas alarm M7626 JISM7626-1994; 1996.
- [6] StorHy. Hydrogen storage systems for automotive application: integrated project number 502667. Available from: <<http://www.storhy.net/>>.
- [7] StorHy. Hydrogen storage systems for automotive application: second periodic activity report. Integrated project number 502667; 19 July 2006.
- [8] Salyk O, Castello P, Harskamp F. A facility for characterization and testing of hydrogen sensors. *Meas Sci Technol* 2006;17:3033–41.
- [9] Castello P, Salyk O. Characterization and application of a facility for independent customer testing of hydrogen sensors. *Int Sci J Alternative Energy Ecology* 2006;5(37): 61–2.
- [10] Castello P, Salyk O. Testing of hydrogen safety sensors in service simulated conditions. International conference on hydrogen. Pisa, Italy: September 8–10; 2005.
- [11] Salyk O, Castello P. Hydrogen sensors in systems for alternative fuels. *Chemicke Listy* 2005;99:116–9.
- [12] Bronkhorst®. High Tech. Fluidat on the net – a collection of routines to calculate physical properties of gases and liquids, <www.fluidat.com/>; 2006.
- [13] Marsh ND, Cleary TG. Preliminary performance assessment of commercially-available hydrogen sensors. In: Proceedings of the international symposium on materials issues in a hydrogen economy. Richmond, VA: November 12–5; 2007.
- [14] CRC handbook of chemistry and physics. 84th ed; 2003–2004. ISBN 0-8493-0484-79.
- [15] MacIntyre I, Tchouvelev AV, Hay DR, Wong J, Grant J, Benard P. Canadian hydrogen safety program. *Int J Hydrogen Energy* 2007;32(13):2134–43.
- [16] Schulte I, Hart D, van der Vorst R. Issues affecting the acceptance of hydrogen fuel. *Int J Hydrogen Energy* 2004; 29(7):677–85.